

**MT Series**  
**MINOX™ Thermocouples**

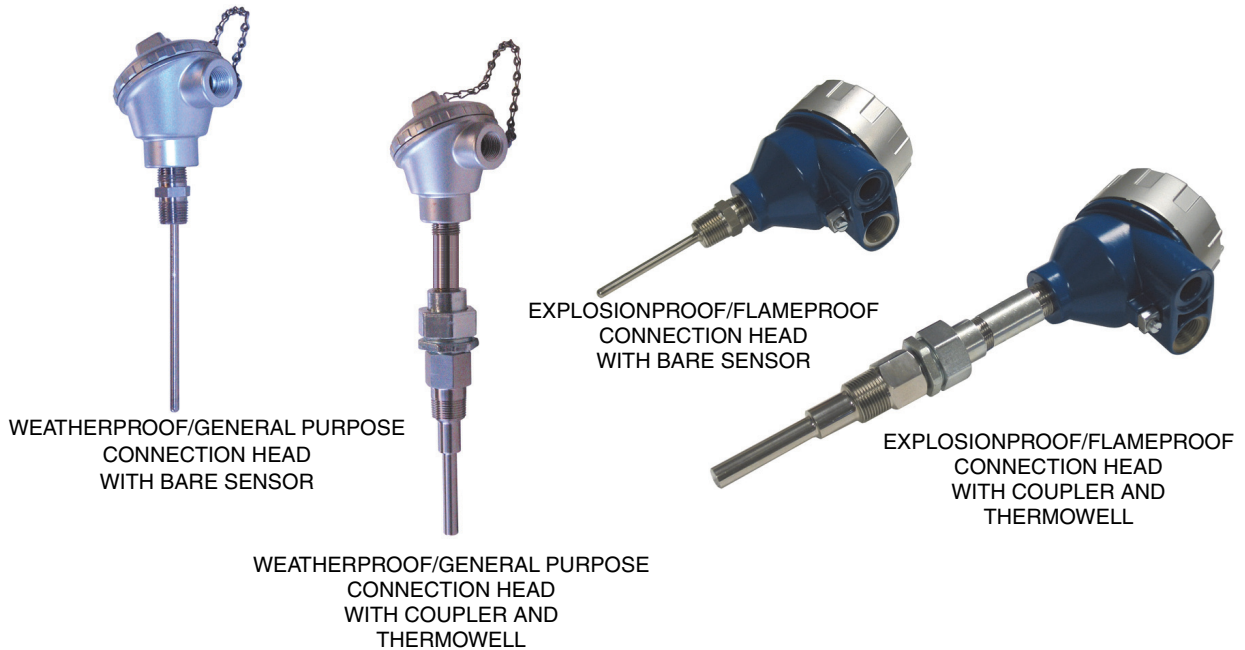

The Foxboro® brand MT Series MINOX™ Thermocouples are available from Invensys. They are thermocouple wires with mineral insulation lightly compacted about the conductors and encased in a metal sheath. MINOX Assemblies are specified because of their strength, protection against corrosion and contaminating atmospheres, and ability to be spring loaded to ensure tip contact at well bottom. The output from the element may be directly connected to a variety of thermocouple temperature measuring instruments.

**DURABLE CONSTRUCTION AND ENVIRONMENTAL PROTECTION**

Thermocouple wires are surrounded by fiberglass insulation and enclosed in a durable metal sheath. The sheath is annealed to remove stresses and increase flexibility. Moisture is removed (and sealed out) from the assembly to provide a high insulation resistance.

**INSTALLATION VERSATILITY**

For angle use, a bare MINOX thermocouple can be bent on a radius as small as 50 mm (2 in). A wide variety of wells is available for use with high-pressure vessels, corrosive, and abrasive applications.

**USABLE WITH A VARIETY OF INSTRUMENTS**

MINOX thermocouples may be directly connected to a variety of Foxboro instruments such as transmitters, converters, controllers, totalizers, or system input modules.

**FAST RESPONSE**

Small size and compact design result in fast response to temperature changes. Spring-loaded MINOX thermocouples used in wells provide a temperature response approximately twice as fast as that of a comparable 0.75 mm<sup>2</sup> or 20 AWG size wire-type thermocouple assembly in a well or in a protection tube. Both earthed (grounded) and isolated junctions are available.

**SPRING LOADED CONSTRUCTION WITH WELLS**

When wells are used, a spring loading device is used to provide positive tip contact between the element and thermowell bottom. This ensures a reliable temperature measurement.

**MANY AGENCY APPROVALS/CERTIFICATIONS**

Approved/Certified by FM, FMc, and CSA for Explosionproof locations; and certified for Flameproof locations by ATEX and IECEx.

**LONG LIFE, LOW MAINTENANCE**

The use of protective sheathing and wells increases the life of the sensor while ensuring low heat loss and suitable thermal response. When wells are used, the spring-loaded thermocouple can be easily removed without process shutdown. Longer sensor life results in lower maintenance costs and reduced spare parts inventory.

**A VARIETY OF CONFIGURATIONS**

The MT Series are available as either bare sheath or well type assemblies. In either configuration, the sensor is protected with a full length moisture resistant sheath of either AISI Type 316 stainless steel (316 ss) or Inconel 600, depending upon the temperature or process material being measured. An excellent selection of specially engineered wells is available to further protect the thermocouple from physical damage or from corrosive or damaging process media. Thermocouple insertion lengths are available from 51 to 914 mm (2 to 36 in) in 12.7 mm (1/2 in) increments. Custom lengths are also available from 37 through 300 inches in whole inch increments. Weatherproof (IEC IP65, NEMA Type 4) terminal connection heads are offered for general purpose applications, and explosionproof/flameproof (IEC IP65, NEMA Type 4X) terminal connection heads are offered for corrosive or hazardous area installations.

**DESIGNATION OF THERMOCOUPLE TYPES**

ISA (a) Designation	Industrial Description	Material Description
Type K	Chromel-Alumel (Yellow +) (Red -)	Nickel-Chromium vs. Nickel-Aluminum (NiCr-NiAl)
Type N	Nicrosil-Nisil (Orange +) (Red -)	Nickel Chrome Silicon vs. Nickel Silicon (NiCrSi-NiSi)
Type J	Iron-Constantan (White +) (Red -)	Iron vs. Copper-Nickel (Fe-CuNi)
Type E	Chromel-Constantan (Purple +) (Red -)	Nickel-Chromium vs. Copper-Nickel (NiCr-CuNi)
Type T	Copper-Constantan (Blue +) (Red -)	Copper vs. Copper-Nickel (Cu-CuNi)

(a) The ISA type designation is also used by NBS (MN125, 1974), ANSI (MC96.1, 1982), ASTM (E230, 1983), and IEC.

PERFORMANCE SPECIFICATIONS

Table 1. Accuracy (Conforms to ANSI MC 96.1)

Thermocouple Type	Temperature Range (a)		Tolerance (b) (Percentages Expressed are of Reading)
	°C	°F	
Type K	-200 to 0 0 to 1150	-328 to +32 32 to 2100	±2.2°C or ±2.0% ±2.2°C or ±0.75%
Type N	-200 to 0 0 to 1150	-328 to +32 32 to 2100	±2.2°C or ±2.0% ±2.2°C or ±0.75%
Type J	0 to 750	32 to 1382	±2.2°C or ±0.75%
Type E	-200 to 0 0 to 900	-328 to +32 32 to 1652	±1.7°C or ±1.0% ±1.7°C or ±0.5%
Type T	-200 to 0 0 to 350	-328 to +32 32 to 662	±1°C or ±1.5% ±1°C or ±0.75%

(a) See Standard Specifications section for temperature limits with different MINOX assembly configurations.

(b) Whichever is greater. The “percent of reading” limit of error applies to the °C temperature only. To determine the error in °F, multiply the °C error by 1.8.

STANDARD SPECIFICATIONS

**MINOX Thermocouple Configurations**

Three configurations are offered: a well-type assembly with a nipple coupler; a well-type assembly with a nipple and union coupler; and a bare element-type assembly. The bare element-type assembly has a hex-head nipple with 1/2 NPT external thread welded on sensor for process mounting and mounting to connection head. See Figure 1.

**Sensor Type**

Single or Dual Element

**Temperature Limits**

Minimum and maximum temperature limits for the thermocouple element, sheaths, and connection head are given below. It is assumed that process temperature determines element and sheath temperature. The user should take into account that a combination of ambient and process temperature may affect connection head temperature, depending on the thermal environment of the installation.

Note that although some elements can operate to a maximum of 1150°C (2100°F), their use with the 316 ss sheath is limited to 870°C (1600°F). For use up to 1150°C (2100°F), the Inconel sheath should be specified.

**ELEMENT**

Refer to “PERFORMANCE SPECIFICATIONS” above.

**CONNECTION HEAD**

-40 and +105°C (-40 and +220°F)

**316 ss SHEATH**

-200 and +870°C (-328 and +1600°F)

**INCONEL SHEATH**

-200 and +1150°C (-328 and +2100°F)

**Calibration**

ANSI MC 96.1, Types K, N, J, E, or T, as specified.

**Grounded Measuring Junction**

The thermocouple wires are welded to the internal surface of the sheath tip.

**Isolated Measuring Junction**

Thermocouple wires are electrically insulated from the sheath. Recommended for most applications.

**Insertion Length, A, U, or U +T**

51 to 914 mm (2.0 to 36 inches) standard; nonstandard lengths to 7.6 m (300 in) available, see Model Code, and Dimensions-Nominal sections.

**Sensitive Length**

40 mm (1.6 in) minimum, measured from closed end.

Figure 1. MT Series MINOX Thermocouple Configurations

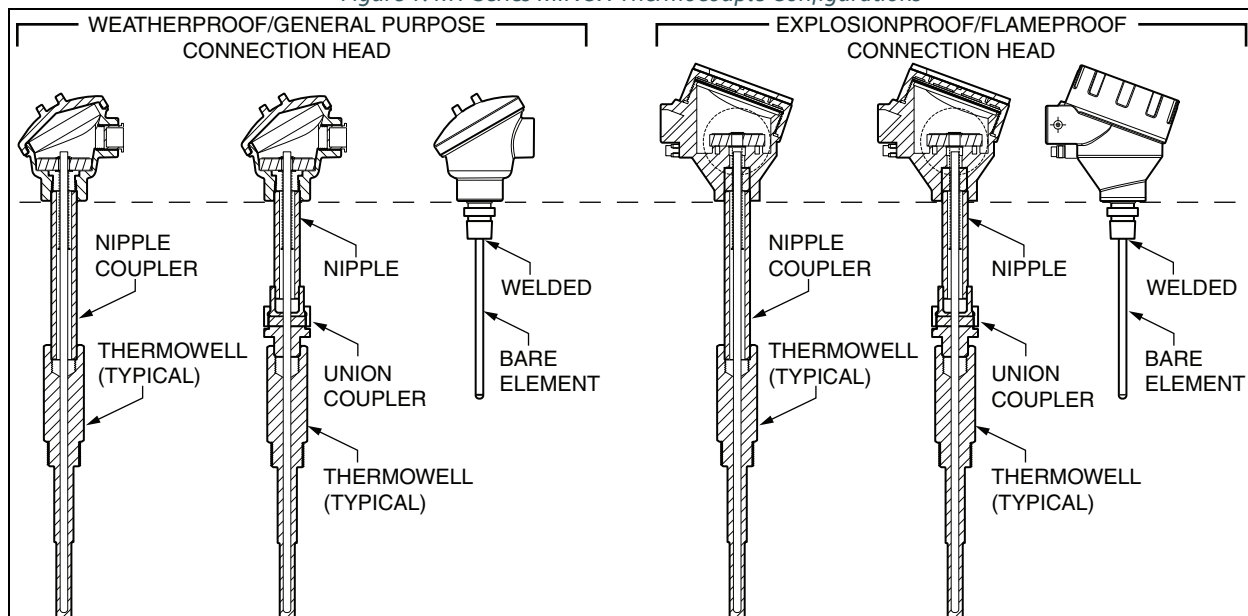

**Sheath Sealant**

Epoxy compound applied at open end of sheath to prevent entry of moisture.

**Sheath Outside Diameter (O.D.)**

6.35 mm (0.250 in). Note that a well inside diameter (I.D.) of 6.60 mm (0.260 in) is required.

**Internal Insulation**

Glass fiber insulation; ungrounded thermocouples also potted in high purity aluminum oxide.

**Construction**

All welded and moisture sealed, 316 ss for temperature up to 870°C (1600°F), and Inconel 600 for temperatures up to 1150°C (2100°F).

**Thermowells**

Foxboro wells isolate the process and separate the temperature-measuring sensitive portion of the thermocouple from potentially corrosive or damaging process media. These wells permit ready removal of the sensor without process shutdown. A selection of plain or lagged, threaded or flanged, solid, welded or tapered wells is available in a variety of sizes and materials. The wells are machined from industry standard 316 ss, and a polished finish assures maximum corrosion resistance. They are manufactured in accordance with applicable ASME, ASTM, and ANSI standards. Refer to PSS 3-3D1 A for T Series Wells, and to PSS 3-3C1 A for W Series Wells. Also see Figure 2.

Figure 2. Typical W-Series and T-Series Wells

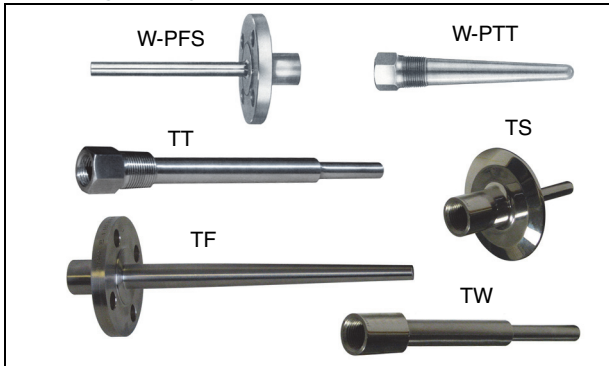

**Dimensions**

See “DIMENSIONS – NOMINAL” on page 9.

**Terminal Block**

A terminal block is located within the connection head. Field wires enter through the 1/2 NPT conduit connection in the head and terminate under screw terminals on the block. The terminal block accommodates either a single or dual element sensor. Refer to Figure 3.

**Weatherproof/General Purpose Connection Head**

When used with a thermowell, this type of connection head contains a compression spring to maintain thermocouple tip contact. The housing is constructed from a diecast aluminum alloy and has an O-ring gasketed cover. A 1/2 NPT conduit connection is provided for field wiring to a ceramic terminal block within the connection head. The assembly meets IEC IP65 and provides the environmental protection of NEMA Type 4. See Figure 1.

**Explosionproof/Flameproof Connection Head**

The explosionproof/flameproof connection head is used to protect conductors in conduit systems within hazardous areas. The head contains a compression spring to maintain thermocouple tip contact. The housing is constructed from a diecast low copper aluminum alloy, painted, and has an O-ring gasketed cover. A 1/2 NPT conduit connection is provided for field wiring to a ceramic terminal block within the connection head. The assembly meets IP65 and provides the environmental and corrosion resistance protection of NEMA Type 4X. See Figure 1.

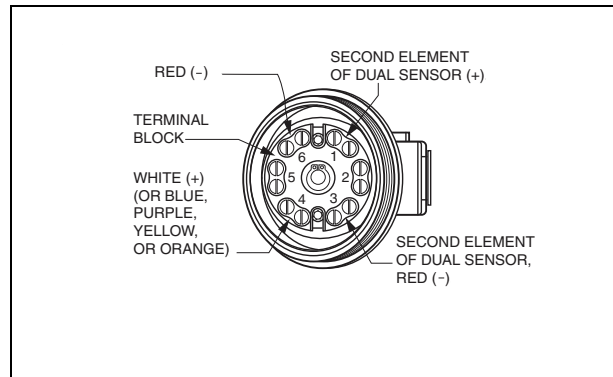

Figure 3. Terminal Block Configuration

**PRODUCT SAFETY SPECIFICATIONS**

*The MINOX thermocouples have been designed to meet the product safety descriptions listed below. For detailed information, or status of testing laboratory approvals/certifications, contact Invensys.*

Testing Laboratory, Types of Protection, and Area Classification	Application Conditions (a)	Connection Head Code (a)
<b>FM</b> and <b>FMc</b> explosionproof for Class I, Division 1, Groups B, C, and D; Dust-ignitionproof for Class II, Division 1, Groups E, F, and G; and Class III, Division 1.	Temperature Class T5; Ta = -50 to +85°C	4
<b>CSA</b> explosionproof for Class I, Division 1, Groups B, C, and D; Dust-ignitionproof for Class II, Division 1, Groups E, F, and G; and Class III, Division 1.	Temperature Class T5; Ta = -40 to +85°C	5
<b>ATEX</b> flameproof; II 1/2 G, Ex d IIC; or II 2 G, Ex d IIC; or II 2 D.	Construction Types N, P, W, and B only. Temperature Class: ▶ T5 (100°C), Ta = -40 to +85°C ▶ T6 (85°C), Ta = -40 to +75°C	6
<b>IECEX</b> flameproof; Ex d IIC	Construction Types N, P, W, and B only. Temperature Class: ▶ T5, Ta = -40 to +85°C ▶ T6, Ta = -40 to +75°C	7

(a) Refer to Model Code for descriptions of Construction Codes and Certifications Codes.

**OPTIONS AND ACCESSORIES**

**Accessory: Thermocouple Replacement Element Assemblies**

To order a replacement element assembly, specify Connection Head type R. To order a replacement element assembly with a bare element, specify Construction type B; otherwise, specify Construction type E.

**Option -A3: Metric Conduit Thread Adapter**

An 1/2 NPT to M20 x 1.5 metric conduit thread adapter is provided for Connection Head types 6 and 7. Select Option -A3.

**Option -C1: Calibration Certificate**

A 3-point calibration with certificate is provided. For standard or special calibration curves, select Option -C1.

**Option -C5: Oxygen Service**

The thermocouple is cleaned and prepared for Oxygen Service. Select Option -C5.

For certification of cleaning, also select Auxiliary Specification Cert G.

**Option -WF: Wake Frequency Calculations**

Wake Frequency calculations are often required to determine if the thermowell is strong enough to withstand the process conditions in the pipeline or vessel. “Von Karman Trail” refers to the turbulent wake which is formed as fluid flows past a thermowell. A vibration frequency is determined depending on the thermowell shank construction and the fluid velocity. Should this frequency exceed the “natural frequency” of the thermowell, it will cause the thermowell to break off. It is therefore necessary that the thermowell selected be such that its “natural frequency” always exceeds the potential wake frequency caused by the process flow. Select Option -WF for wake frequency calculations.

## MODEL CODE

## MODEL CODE

<u>Description</u>	<u>Model</u>
MINOX Thermocouple	MT
<b><u>Sensor Type (a)</u></b>	
Single Element	-1
Dual Element	-2
<b><u>Connection Head (a)</u></b>	
Weatherproof/General Purpose	3
Explosionproof and Weatherproof, FM and FMc Approvals (b)	4
Explosionproof and Weatherproof, CSA Certification (b)	5
Flameproof and Weatherproof, ATEX Certification (b) (c)	6
Flameproof and Weatherproof, IECEx Certification (b) (c)	7
Replacement Sensor (No Connection Head) (d)	R
<b><u>Construction (a)</u></b>	
Well Type, Nipple Coupler, steel (for connection to Well) (e)	N
Well Type, Nipple Coupler, 316 ss (for connection to Well) (e)	P
Well Type, Union Coupler, steel (for connection to Well) (c) (e)	U
Well Type, Union Coupler, 316 ss (for connection to Well) (e)	W
Bare Element with 316Lss threaded hex fitting (1/2 NPT external thread) welded on to sensor (f)	B
None (g); Replacement Sensor for use with Thermowell	E
<b><u>Thermocouple Type (h)</u></b>	
Type E	E
Type J	J
Type K	K
Type N	N
Type T	T
<b><u>Measuring Junction</u></b>	
Isolated	I
Grounded (Earthed) - Not with Type T Thermocouple	G
<b><u>Sheath - 6.35 mm (0.25 in) O.D.</u></b>	
316 ss	S
Inconel	I
<b><u>Length "U" or "U + T" Dimension (i)</u></b>	
51 mm (2.0 in)	-002
76 mm (3.0 in)	-00A
90 mm (3.5 in)	-003
102 mm (4 in)	-004
127 mm (5 in)	-005
152 mm (6 in)	-006
178 mm (7 in)	-007
203 mm (8 in)	-008
229 mm (9 in)	-009
254 mm (10 in)	-010
279 mm (11 in)	-011
305 mm (12 in)	-012
330 mm (13 in)	-013
356 mm (14 in)	-014
381 mm (15 in)	-015
406 mm (16 in)	-016
432 mm (17 in)	-017
457 mm (18 in)	-018

MODEL CODE (CONTINUED)

Description	Model
<b>Length “U” or “U &amp; T” Dimension (Cont.) (i)</b>	
483 mm (19 in)	-019
508 mm (20 in)	-020
533 mm (21 in)	-021
559 mm (22 in)	-022
584 mm (23 in)	-023
610 mm (24 in)	-024
635 mm (25 in)	-025
787 mm (31 in)	-031
660 mm (26 in)	-026
686 mm (27 in)	-027
711 mm (28 in)	-028
737 mm (29 in)	-029
762 mm (30 in)	-030
813 mm (32 in)	-032
838 mm (33 in)	-033
864 mm (34 in)	-034
889 mm (35 in)	-035
914 mm (36 in)	-036
Nonstandard length are whole inches from 37 through 300 inches; specify desired length by substituting numerical values for Xs; e.g., -048 = 48 inches	-XXX
<b>Optional Selections</b>	
Sensor Length 0.5 in longer than the specified length; not available with Length Codes 00A or 003	-H
Shipped without Thermowell; for customer to install thermowell (j)	-W
Thermowell other than the Standard -T Series Wells	-X
Wake Frequency Calculation (k)	-WF
Metric Conduit Thread Adapter (1/2 NPT by M20 X 1.5) (l)	-A3
Three Point Calibration with Certificate	-C1
Cleaned and Prepared for Oxygen Service (m)	-C5
Examples: MT-13NEIS-012-C1; MT-14BJGS-024-WFC1	

- (a) See Figure 1 and “DIMENSIONS – NOMINAL” on page 9 for thermocouple assembly configurations.
- (b) Thermowells for Explosionproof/Flameproof atmospheres are only available in the following materials: carbon steel C-1018, 316 ss, 316L ss, 304 ss, 304L ss, Alloy 20 Cb-3, nickel alloy equivalent to Hastelloy® B, nickel alloy equivalent to Hastelloy® C-276, Inconel™ 600, R-Monel™ 405, K-Monel™ 500, Nickel 200, Titanium, and Cr/Moly steels. Hastelloy is a registered trademark of Haynes International, Inc.
- (c) ATEX and IECEx, d, not available with Construction Code U, carbon steel union coupler.
- (d) Use only with Construction Codes B or E.
- (e) For Well Type construction, the well must be specified separately. Refer to “STANDARD SPECIFICATIONS” on page 3.
- (f) Use for Bare Sensor replacement when Connection Head type R is used
- (g) Use only with Connection Head type R. Used for replacement of sensors for Construction types N, P, U and W.
- (h) See “PERFORMANCE SPECIFICATIONS” on page 3 for Calibration Curve Accuracy.
- (i) With a bare sheath assembly, the “U” or “U + T” dimension is identified as the “A” dimension. See DIMENSIONS-NOMINAL section.
- (j) No Agency electrical safety certifications required.
- (k) Not available with Construction B (Bare Element). Requires completed data sheet, available to download at [http://iom.invensys.com/EN/pdfLibrary/Datasheet\\_Foxboro\\_ThermowellWakeFrequency\\_04-11.pdf](http://iom.invensys.com/EN/pdfLibrary/Datasheet_Foxboro_ThermowellWakeFrequency_04-11.pdf).
- (l) Option -A3 is only available with Connection Head types 6 and 7.
- (m) Customer is responsible for cleaning of customer supplied thermowells. For certification of cleaning, select Auxiliary Specification Cert G.



$\frac{\text{mm}}{\text{in}}$

**WEATHERPROOF/GENERAL PURPOSE CONNECTION HEAD**

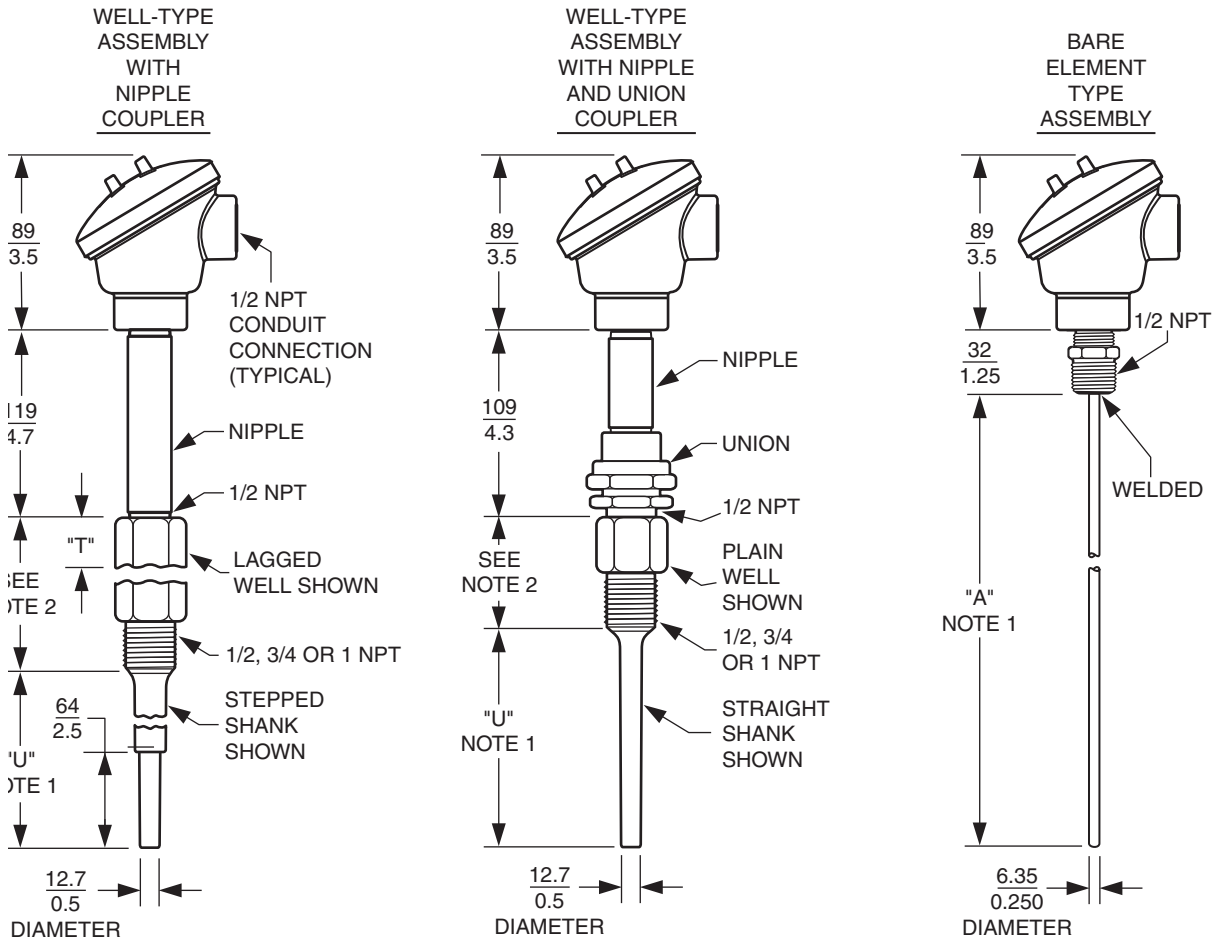

**NOTES**

1. U = Insertion Length (with well); and A = Bare Sensor Length (without well).
2. A lagged well has a lagging length, T, that is in addition to the length of a plain well, as shown in the two well-type assembly illustrations. The dimension indicated varies depending on the lagging length. This dimension without lagging is nominally 51 mm (2.0 in). For a lagged well, the nominal dimension is 51 mm (2.0 in) plus lagging length T.

mm  
in

**EXPLOSIONPROOF/FLAMEPROOF CONNECTION HEAD**

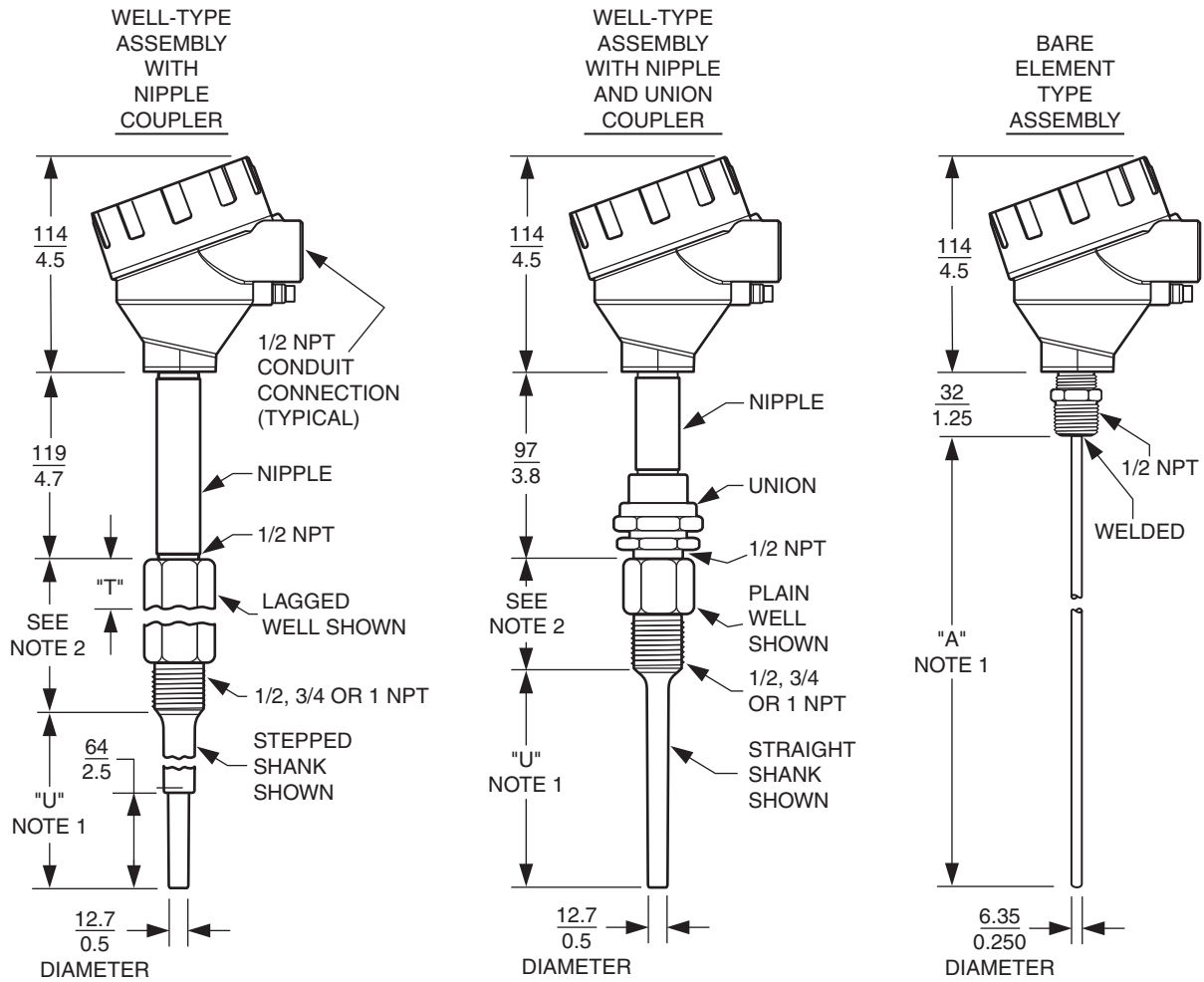

**NOTES**

1. U = Insertion Length (with well); and A = Bare Sensor Length (without well).
2. A lagged well has a lagging length, T, that is in addition to the length of a plain well, as shown in the two well-type assembly illustrations. The dimension indicated varies depending on the lagging length. This dimension without lagging is nominally 51 mm (2.0 in). For a lagged well, the nominal dimension is 51 mm (2.0 in) plus lagging length T.

NOTES

### ORDERING INSTRUCTIONS

1. Model Number
2. Well, as required (refer to PSS 3-3D1 A for Standard “T” Series Wells, and to PSS 3-3C1 A for “W” Series Wells).
3. Accessories
4. User Tag Data

### OTHER FOXBORO TEMPERATURE MEASUREMENT SENSORS

PSS 1-1B1 A      PR Series Platinum RTDs  
PSS 3-3A1 A      Filled Thermal Systems

### OTHER M&I PRODUCTS

Invensys provides a broad range of measurement and instrument products, including solutions for pressure, flow, analytical, positioners, temperature, controlling and recording. For a listing of these offerings, visit our web site at:

[www.invensys.com](http://www.invensys.com)