

**Foxboro<sup>®</sup> Model 9600A Magnetic Flow Sensor  
for hygienic and sanitary applications**



The 9600A magnetic flow sensor can be used with IMT30A, IMT31A and IMT33A magnetic flow converter.

- ▶ Robust stainless steel housing for hygienic and aseptic operation
- ▶ Fully suitable for CIP and SIP
- ▶ Typical food & beverage and pharmaceutical process connections and insertion lengths

<b>1</b>	<b>Product features</b>	<b>3</b>
<hr/>		
1.1	Sanitary and hygienic solution .....	3
1.2	Options .....	5
1.3	Measuring principle.....	6
<b>2</b>	<b>Technical data</b>	<b>7</b>
<hr/>		
2.1	Technical data.....	7
2.2	Dimensions and weights .....	11
2.3	Measuring accuracy .....	24
<b>3</b>	<b>Installation</b>	<b>25</b>
<hr/>		
3.1	Intended use .....	25
3.2	General notes on installation .....	25
3.2.1	Vibration .....	25
3.2.2	Magnetic field.....	25
3.3	Installation conditions .....	26
3.3.1	Inlet and outlet .....	26
3.3.2	Bends in 2 or 3 dimensions.....	26
3.3.3	T-section .....	26
3.3.4	Bends .....	27
3.3.5	Open discharge .....	28
3.3.6	Control valve .....	28
3.3.7	Pump .....	28
3.3.8	Air venting and vacuum forces .....	29
3.3.9	Mounting requirements for self-draining .....	30
3.3.10	Flange deviation .....	31
3.3.11	Mounting position.....	31
3.4	Mounting.....	32
3.4.1	Torques and pressures.....	32
3.4.2	Installation of weld-on versions .....	34
3.4.3	Temperatures .....	34
3.4.4	Cleaning .....	35
<b>4</b>	<b>Electrical connections</b>	<b>36</b>
<hr/>		
4.1	Safety instructions.....	36
4.2	Grounding .....	36
4.3	Virtual reference for IMT33A (C, W and F version) .....	37
4.4	Connection diagrams .....	37
<b>5</b>	<b>Model code</b>	<b>38</b>
<hr/>		

## 1.1 Sanitary and hygienic solution

The **9600A** electromagnetic flow sensor is specifically designed to stay clean and sterile in compliance with the most stringent demands prevailing in the food & beverages and pharmaceutical industries. There are no crevices, gaps or blind spots and the flow sensor offers full CIP/SIP possibilities. The flow sensor is conform FDA food contact material requirements, for all wetted materials and is certified in accordance with EHEDG and 3A.

The flowmeter provides easy installation and commissioning and is available with the flow converter separate, or mounted directly on the flow sensor. Therefore it can be installed in places difficult to access due to for example high temperatures or vibrations. The converter is also available in a stainless steel housing for applications when for example regular cleaning procedures with aggressive cleaning agents, may attack a standard polyurethane coating.

In addition to weld-end connections, this Foxboro flow meter offers a large number of other hygienic connections, including DIN 11851, DIN 11864, clamp and SMS.

Because of its high accuracy, a precise measurement of the medium is possible enabling an accurate measurement of flows whether it is required for blending, dosing or batching. Furthermore its accuracy is maintained even in case of pulsating flows. When a medium has a low conductivity for example in case of glucose or fruit concentrates, the device continues to deliver an optimal performance.

Due to its reinforced liner the 9600A is an optimal solution for applications where high temperatures or vacuum impacts can occur. The certified hygienic construction is also available for larger diameters up to DN150, as volumes are increasing and larger pipe sizes are needed with fast increase in the industrial production of beer, wine, milk and other beverages.



**Highlights**

- Robust stainless steel housing for hygienic and aseptic operation
- PFA liner reinforced with embedded stainless steel grid for vacuum resistance
- High form stability for good accuracy even with high pressures
- Unique L-shaped gasket extends lifetime by preventing protrusion into measurement tube
- Wide choice of the electrode materials, even for extreme chemical applications.
- Simple and effective CIP / SIP
- Typical food and beverages and pharmaceutical process connections and insertion lengths
- Large diameter range DN2.5 up to DN150, to suit any F&B application
- All wetted materials are conform EC 1935/2004 and FDA food contact material regulation.
- Optimal hygienic performance conforming to EHEDG and 3A certification.
- Able to measure at low conductivity  $\geq 1 \mu\text{S}/\text{cm}$  (for demin water  $\geq 20 \mu\text{S}/\text{cm}$ )
- Wide process temperature range -40 up to 140°C

**Industries**

- Food & Beverages
- Pharmaceutical
- Cosmetics

**Applications**

- Exact blending, dosing and batching
- Beverages including soft drinks, beer, wine and fruits juices
- Milk and other dairy products
- Beverages containing solids (for example yoghurt containing cereals)
- Drugs, caustic sodas, acids, proteins, antibiotics
- CIP media including acids and caustic solutions
- For large-scale production plants with diameter up to DN150

## 1.2 Options



### Reinforced PFA liner

The 9600A has an FDA conform PFA liner with an integrated stainless steel reinforcement that ensures vacuum resistance and long-term dimensional stability. The reinforced PFA liner makes sure that the flowmeter keeps its form stability even at high temperatures and very low pressure or vacuum. Therefore the 9600A remains its accuracy over time.

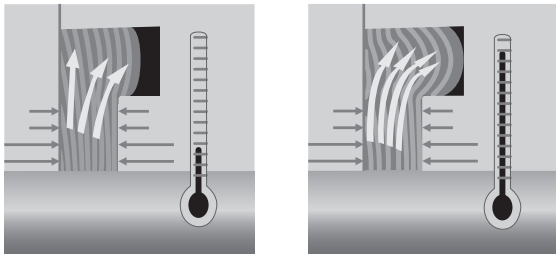

### Unique gasket adapter concept

A special sealing concept for stainless steel adapters has been designed with support of TNO, a member of the European EHEDG organization. The sealing concept provides for a smooth and dimensionally stable measuring section between the two process connections. It prevents the gasket from expanding into the measuring tube because during CIP / SIP cleaning procedures, the gasket expands into an expansion chamber. This leads to a sharp sealing at the edge of the pipeline and a perfect transition into the measuring section. In addition, the gasket experiences less stress which results in a longer life time and reduced maintenance.

### 1.3 Measuring principle

An electrically conductive fluid flows inside an electrically insulated pipe through a magnetic field. This magnetic field is generated by a current, flowing through a pair of field coils.

Inside of the fluid, a voltage  $U$  is generated:

$$U = v * k * B * D$$

in which:

$v$  = mean flow velocity

$k$  = factor correcting for geometry

$B$  = magnetic field strength

$D$  = inner diameter of flowmeter

The signal voltage  $U$  is picked off by electrodes and is proportional to the mean flow velocity  $v$  and thus the flow rate  $q$ . A signal converter is used to amplify the signal voltage, filter it and convert it into signals for totalizing, recording and output processing.

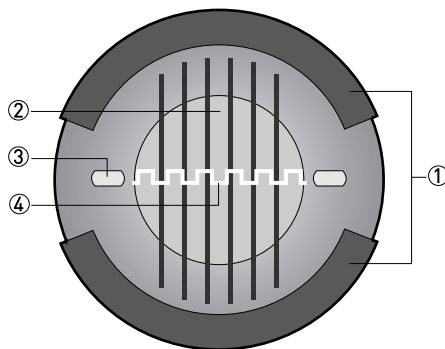

Figure 1-1: Measuring principle

- ① Field coils
- ② Magnetic field
- ③ Electrodes
- ④ Induced voltage [proportional to flow velocity]

## 2.1 Technical data

- *The following data is provided for general applications. If you require data that is more relevant to your specific application, please contact us or your local sales office.*
- *Additional information (certificates, special tools, software,...) and complete product documentation can be downloaded free of charge from the website.*

### Measuring system

Measuring principle	Faraday's law of induction
Application range	Electrically conductive fluids
<b>Measured value</b>	
Primary measured value	Flow velocity
Secondary measured value	Volume flow

### Design

Features	Hygienic design
	Stainless steel housing
	Food & beverage and pharmaceutical process connections
Modular construction	The measurement system consists of a flow sensor and a signal converter. It is available as compact and as separate version.
Compact version	With signal converter: IMT30A
	With signal converter: IMT31A
	With signal converter: IMT33A
Remote version	In wall (W) mount version with signal converter: IMT30A
	In wall (W) mount version with signal converter: IMT31A
	In field (F), wall (W) or rack (R) mount version with signal converter: IMT33A
Nominal diameter	DN2.5...150 / 1/10"...6"
Measuring range	-12...+12 m/s / -40...+40 ft/s

### Measuring accuracy

Reference conditions	Flow conditions similar to EN 29104
	Medium: Water
	Temperature: +10...+30°C / +50...+86°F
	Operating pressure: 1 bar / 14.5 psig
	Inlet section: ≥ 5 DN
	Electrical conductivity: ≥ 300 µS/cm
	Wet calibrated on EN 17025 accredited calibration rig by direct volume comparison.

Accuracy curves	Related to volume flow (MV = Measured Value)
	These values are related to the pulse / frequency output.
	The additional typical measuring deviation for the current output is $\pm 10 \mu\text{A}$ .
	For detailed information refer to <i>Measuring accuracy</i> on page 24.
Repeatability	$\pm 0.1\%$ of MV, minimum 1 mm/s
Long term stability	$\pm 0.1\%$ of MV

### Operating conditions

<b>Temperature</b>	
Process temperature	Separate flow sensor: $-40\dots+140^\circ\text{C}$ / $-40\dots+284^\circ\text{F}$
	Compact with IMT33A converter: $-40\dots+140^\circ\text{C}$ / $-40\dots+284^\circ\text{F}$
	Compact with IMT30A - IMT31A converter: $-40\dots+120^\circ\text{C}$ / $-40\dots+248^\circ\text{F}$
	For detailed information refer to <i>Temperatures</i> on page 34. For Ex versions different temperatures are valid. Please check the relevant Ex documentation for details.
Ambient temperature	$-40\dots+65^\circ\text{C}$ / $-40\dots+149^\circ\text{F}$
Storage temperature	$-50\dots+70^\circ\text{C}$ / $-58\dots+158^\circ\text{F}$
<b>Pressure</b>	
Ambient pressure	Atmospheric
Nominal flange pressure	For detailed information refer to <i>Dimensions and weights</i> on page 11.
Vacuum load	0 mbar / 0 psi
<b>Chemical properties</b>	
Physical condition	Electrical Conductive liquids
Electrical conductivity	Standard: $\geq 1 \mu\text{S}/\text{cm}$
	Water: $\geq 20 \mu\text{S}/\text{cm}$
Permissible gas content (volume)	IMT30A: $\leq 3\%$
	IMT31A: $\leq 3\%$
	IMT33A: $\leq 5\%$
Permissible solid content (volume)	IMT30A: $\leq 10\%$
	IMT31A: $\leq 10\%$
	IMT33A: $\leq 70\%$

### Installation conditions

Installation	Assure that the flow sensor is always fully filled.
	For detailed information refer to <i>Installation</i> on page 25.
Flow direction	Forward and reverse
	Arrow on flow sensor indicates positive flow direction.
Inlet run	$\geq 5 \text{ DN}$
Outlet run	$\geq 2 \text{ DN}$
Dimensions and weights	For detailed information refer to <i>Dimensions and weights</i> on page 11.



**Materials**

Sensor housing	DN2.5...15: Stainless steel Duplex (1.4462)
	DN25...150: Stainless steel AISI 304 (1.4301)
Measuring tube	Stainless steel AISI 304 (1.4301)
Adapters	Stainless steel AISI 316 L (1.4404)
Liner	PFA
Connection box (F-version only)	<b>Standard:</b> Aluminum, Polyurethane coated
	<b>Option:</b> Stainless steel AISI (1.4408)
Electrodes	<b>Standard:</b> Hastelloy® C
	<b>Option:</b> Hastelloy® B2, platinum, stainless steel, tantalum, titanium
Gaskets	<b>Standard:</b> EPDM FDA recommends EPDM gaskets only if medium ≤ 8% fat.
	<b>Option:</b> Silicone (non-Ex only)

**Process connections**

DIN 11850 row 2 / 11866 row A	DN2.5...150
DIN 11851	DN2.5...150
DIN 11864-2A flange with notch	DN25...150
DIN 32676	DN25...150
ISO 2037	DN2.5...150
ISO 2852	DN2.5...150
SMS 1145	DN2.5...100
Tri Clamp	1/10"...6"
Note: sensor diameters < DN10 have DN10 connections, which means the sensor diameter is smaller.	

**Electrical connections**

<b>Signal cable</b>	
Type A (DS)	Standard cable, double shielded. Max. length: 600 m / 1950 ft (dep. on electrical conductivity and measuring sensor). See documentation of the converter for more information.
Type B (BTS)	Optional cable, triple shielded. Max. length: 600 m / 1950 ft (dep. on electrical conductivity and measuring sensor). See documentation of the converter for more information.

## Approvals and certificates

<b>CE</b>	
This device fulfills the statutory requirements of the EU directives. The manufacturer certifies successful testing of the product by applying the CE mark.	
	For full information of the EU directive & standards and the approved certifications; see the CE declaration or the manufacturer website.
<b>Hazardous areas</b>	
ATEX	Please check the relevant Ex documentation for details.
	<b>Compact version with IMT33A C converter:</b>
	II 2 G, II D, II 2 (1) G
	<b>Remote (F) version:</b>
	II 2 G, II 2 D
FM	<b>In combination with IMT33A C or F converter:</b>
	Class I, Div. 2, Groups A, B, C and D
	Class II, Div. 2, Groups F and G
	Class III, Div. 2, Groups F and G
	Only available for DN2.5...15
CSA	<b>In combination with IMT33A C or F converter:</b>
	Class I, Div. 2, Groups A, B, C and D
	Class II, Div. 2, Groups F and G
	Class III, Div. 2, Groups F and G
	Only available for DN2.5...15
<b>Other approvals and standards</b>	
Protection category acc. to IEC 529/ EN 60529	<b>Standard</b>
	IP 66/67 (NEMA 4/4X/6)
	<b>Option (F version only)</b>
	IP 68 field (NEMA 6P)
	IP 68 factory (NEMA 6P)
	IP 68 is only available for separate design and with a stainless steel connection box.
Hygienic	3A approved
	EHEDG
Shock test	IEC 68-2-27
	30 g for 18 ms
Vibration test	IEC 68-2-64
	f = 20 - 2000 Hz, rms = 4.5 g, t = 30 min.

## 2.2 Dimensions and weights

DIN 11850 (row 2 or DIN 11866 row A)

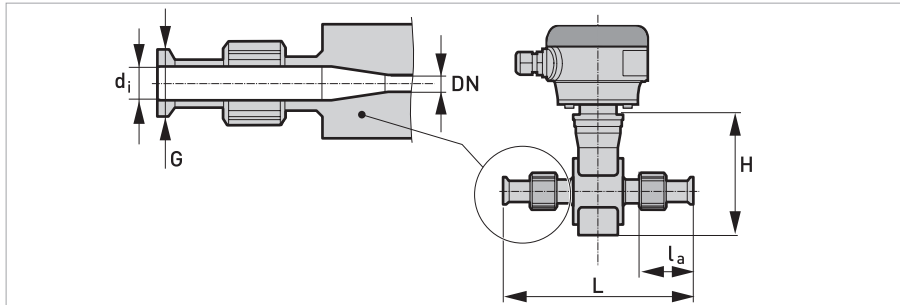

DN2.5...10 screwed adapter with DN10 process connections / DN15 screwed adapter

Nominal size		Dimensions [mm]						Approx. weight [kg]
		Adapter			Flowmeter			
DN	PN	d <sub>i</sub>	G	l <sub>a</sub>	L	H	W	
2.5...10	40	10	13	32	180	120	44	1.5
15	40	16	19	32	180	120	44	1.5

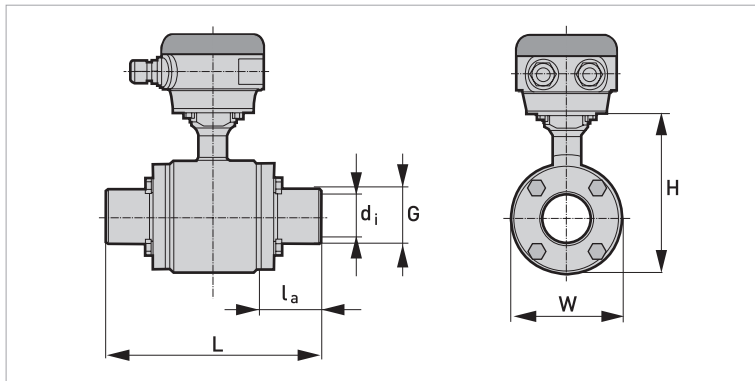

DN25...150 bolted adapter

Nominal size		Dimensions [mm]						Approx. weight [kg]
		Adapter			Flowmeter			
DN	PN	$d_i$	G	$l_a$	L	H	W	
25	40	26	29	20.6	132.6	128	89	3
40	40	38	41	61.3	220	153	114	5.3
50	25	50	53	61.3	220	153	114	6.8
65	25	66	70	41.8	220	180	141	10.9
80	25	81	85	66.8	280	191	152	11.2
100	16	100	104	59.3	280	242	203	18.4
125	10	125	129	66.3	319	258	219	29.5
150	10	150	154	64.3	325	293	254	44.3

DIN 11851

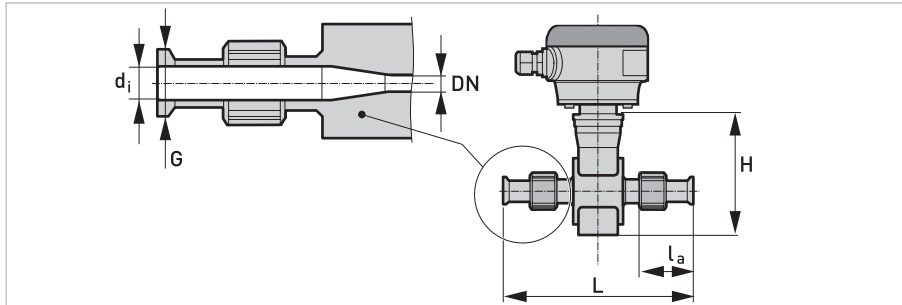

DN2.5...10 screwed adapter with DN10 process connections / DN15 screwed adapter

Nominal size		Dimensions [mm]						Approx. weight [kg]
		Adapter		Flowmeter				
DN	PN	d <sub>i</sub>	G	l <sub>a</sub>	L	H	W	
2.5...10	40	10	Rd 28 x 1/8"	53.1	214	142	44	1.5
15	40	16	Rd 34 x 1/8"	53.1	214	142	44	1.5

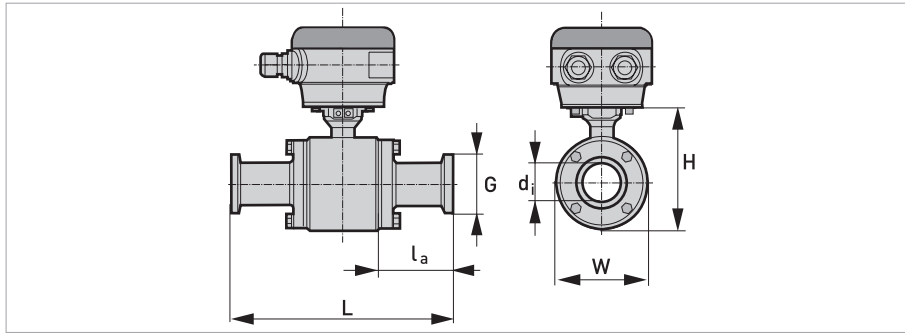

DN25...150 bolted adapter

Nominal size		Dimensions [mm]						Approx. weight [kg]
		Adapter			Flowmeter			
DN	PN	di	G	la	L	H	W	
25	40	26	Rd 52 x 1/6"	49.3	190	128	89	3.2
40	40	38	Rd 65 x 1/6"	91.3	280	153	114	5.5
50	25	50	Rd 78 x 1/6"	93.3	284	153	114	5.3
65	25	66	Rd 95 x 1/6"	77.8	292	180	141	10
80	25	81	Rd 110 x 1/4"	107.8	362	191	152	12.5
100	16	100	Rd 130 x 1/4"	109.3	380	242	203	21.8
125	10	On request						
150	10	On request						

DIN 11864-2A

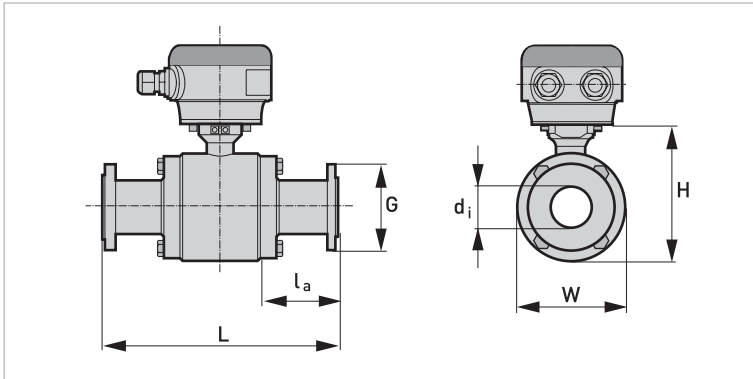

DN25...150 bolted adapter

Nominal size		Dimensions [mm]						Approx. weight [kg]
		Adapter			Flowmeter			
DN	PN	d <sub>i</sub>	G	l <sub>a</sub>	L	H	W	
25	40	26	70	45.8	183	128	89	4.4
40	25	38	82	83.3	264	153	114	7.5
50	25	50	94	83.3	264	153	114	9
65	25	66	113	63.8	264	180	141	14.5
80	25	81	133	122.8	392	191	152	18.6
100	16	100	159	115.3	392	242	203	28.2
125	10	125	183	121	429	259	219	35
150	10	150	213	127	450	294	254	52

DIN 32676

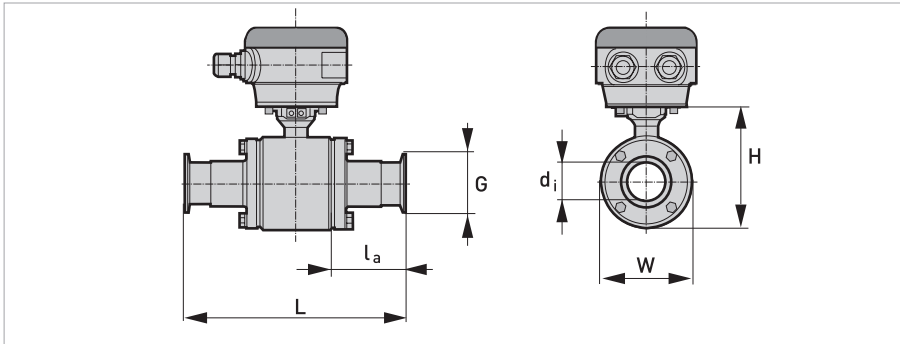

DN25...100 bolted adapter

Nominal size		Dimensions [mm]						Approx. weight [kg]
		Adapter			Flowmeter			
DN	PN	$d_i$	G	$l_a$	L	H	W	
25	16	26	50.5	41.8	175	128	89	3.2
40	16	38	50.5	80.8	259	153	114	5.5
50	16	50	64	80.8	259	153	114	5.3
65	16	66	91	67.8	272	180	141	10
80	16	81	106	92.8	332	191	152	12.5
100	16	100	119	85.3	332	242	203	21.8
125	16	125	155	90	366	259	219	30
150	16	150	213	127	450	294	254	45



ISO 2037

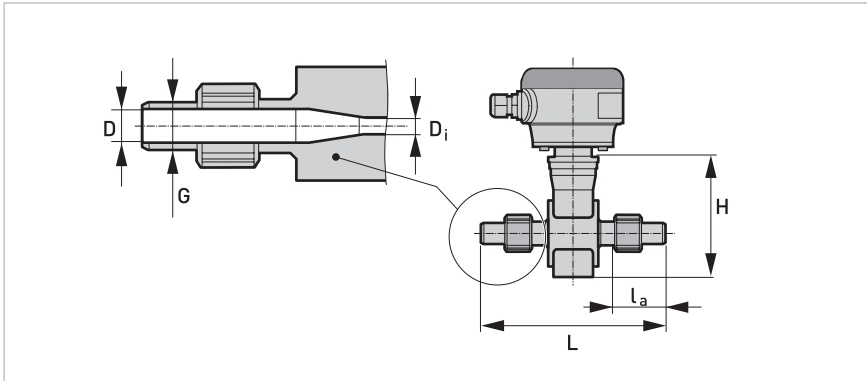

DN2.5...10 screwed adapter with DN10 process connections / DN17.2 screwed adapter

Nominal size		Dimensions [mm]						Approx. weights [kg]
		Adapter			Flowmeter			
DN	PN	$d_i$	G	$l_a$	L	H	W	
2.5...12	40	10	15	32	180	142	44	1.5
17.2	40	16	21	32	180	142	44	1.5

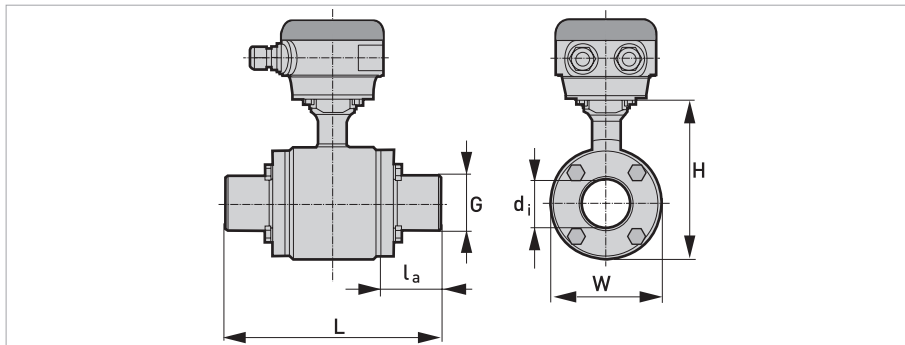

DN25...150 bolted adapter

Nominal size		Dimensions [mm]						Approx. weights [kg]
		Adapter			Flowmeter			
DN	PN	d <sub>i</sub>	G	l <sub>a</sub>	L	H	W	
25	40	22.6	31	20.6	132.6	128	89	3
38	40	38	43	61.3	220	153	114	5.3
51	25	49	55	61.3	220	153	114	5
63.5	25	60.3	71	41.8	220	180	141	9
76.1	25	72.9	86	66.8	280	191	152	10.8
101.6	16	97.6	105	59.3	280	242	203	18.4
114.3	10	110.3	130	66.3	319	258	219	29.5
139.7	10	135.7	156	64.3	325	293	254	44.3

ISO 2852

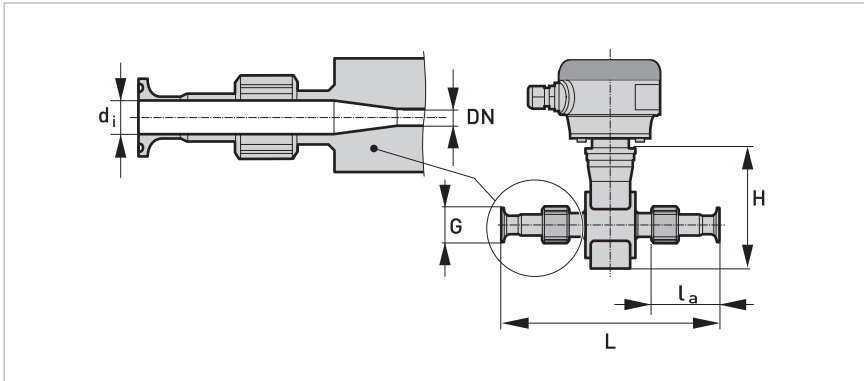

DN2.5...10 screwed adapter with DN10 process connections / DN17.2 screwed adapter

Nominal size			Dimensions [mm]						Approx. weight
DN	[Inch]	PN	Adapter			Flowmeter			
DN	[Inch]	PN	$d_i$	G	$l_a$	L	H	W	[kg]
2.5...10	1/10" .. 3/8"	16	10	34	51.6	219	142	44	1.8
17.2	1/2"	16	16	34	51.6	219	142	44	1.8

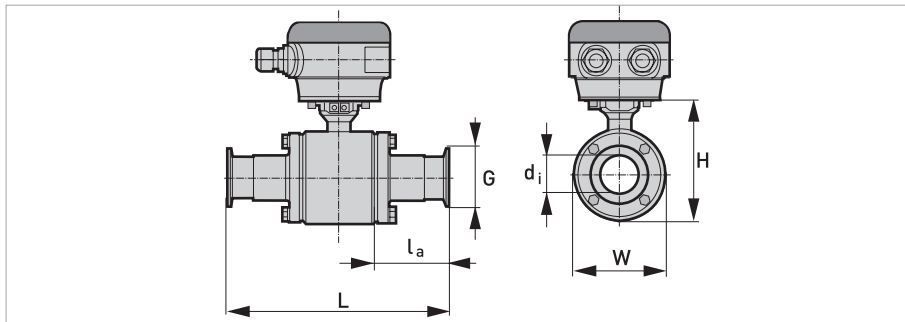

DN25...150 bolted adapter

Nominal size			Dimensions [mm]						Approx. weight [kg]
			Adapter			Flowmeter			
DN	[Inch]	PN	$d_i$	G	$l_a$	L	H	W	
25	1"	16	22.6	50,5	41.8	175	128	89	3.3
38	1.5"	16	35.6	50,5	87.8	273	153	114	5.4
50	2"	16	48.6	64	87.8	273	153	114	5.2
63.5	2.5"	10	60.3	77.5	68.3	273	180	141	9.5
76.1	3"	10	72.9	91	93.3	333	191	152	11.2
101.6	4"	8	97.6	119	85.8	333	242	203	19.1
114.3	5"	5	110.3	211	90	366	259	219	30
139.7	6"	5	135.7	246	90	376	294	254	45

Tri Clamp

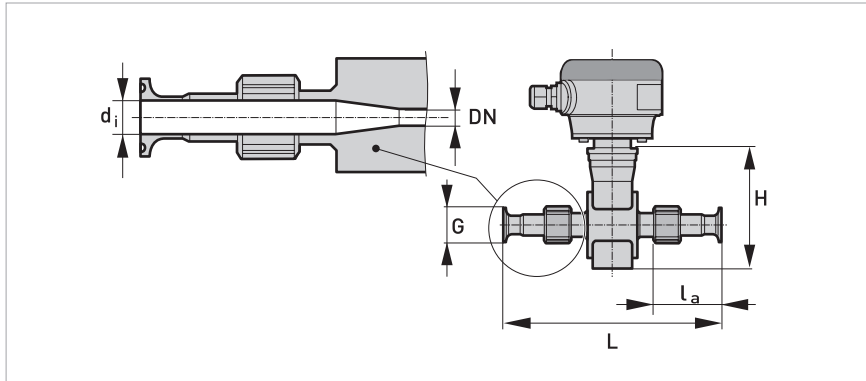

DN 1/2...3/4 screwed adapter

Nominal size		Dimensions [inch]						Approx. weight [kg]
		Adapter			Flowmeter			
DN	PN	$d_i$	G	$l_a$	L	H	W	
1/10" ... 3/8"	20	0.37	0.98	1.97	8.5	5.59	1.73	1.5
1/2"	20	0.62	0.98	1.97	8.5	5.59	1.73	1.5

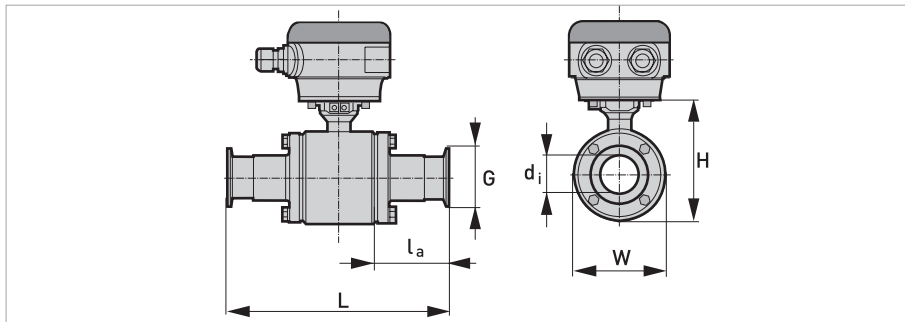

DN1...4" bolted adapter

Nominal size		Dimensions [inch]						Approx. weight [kg]
		Adapter			Flowmeter			
DN	PN	$d_i$	G	$l_a$	L	H	W	
1"	20	0.85	1.98	1.02	5.64	5.04	3.5	3.2
1½"	20	1.35	1.98	3.46	10.75	6.02	4.49	5.5
2"	20	1.85	2.52	3.46	10.75	6.02	4.49	5.3
2½"	20	2.35	3.05	2.69	11.5	7.09	5.55	10
3"	20	2.85	3.54	3.68	14.25	7.52	5.98	12.5
4"	12	3.83	4.68	3.38	14.96	9.53	7.99	21.8
5"	'-	4.78	5.69	3.54	14.43	10.20	8.62	30
6"	'-	5.78	6.57	3.62	14.98	11.57	10.00	45

SMS 1145 Adapter

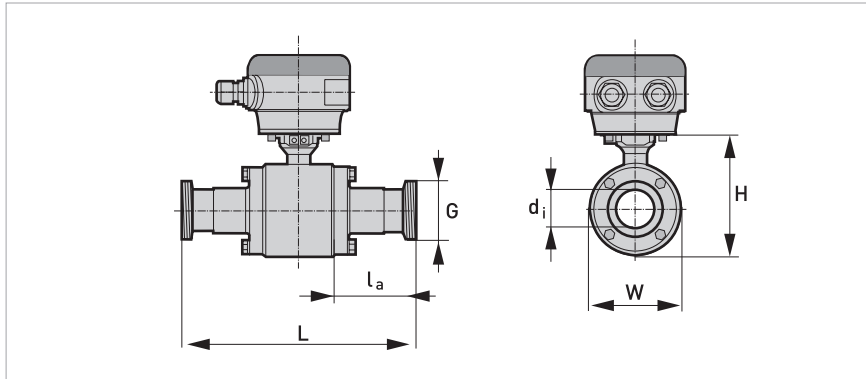

DN25...100 bolted adapter

Nominal size		Dimensions [mm]						Approx. weight [kg]
		Adapter			Flowmeter			
DN	PN	d <sub>i</sub>	G	l <sub>a</sub>	L	H	W	
2.5	39	10	Rd 40-6	53	226	128	44	2
4	39	10	Rd 40-6	53	226	128	44	2
6	39	10	Rd 40-6	53	226	128	44	2
10	6	10	Rd 40-6	53	226	128	44	2
15	6	10	Rd 40-6	53	226	128	44	2
25	6	22.6	Rd 40-6	28.1	147.6	128	89	3.2
38	6	35.5	Rd 60-6	54	262	153	114	5.7
51	6	48.6	Rd 70-6	84.3	266	153	114	5.4
63.5	6	60.3	Rd 85-6	69.8	276	180	141	9.9
76	6	72.9	Rd 98-6	99.8	346	191	152	12.1
100	6	97.6	Rd 132-6	44	336	242	203	21.9

### 2.3 Measuring accuracy

**Reference conditions**

- Medium: water
- Temperature: 20°C / 68°F
- Pressure: 1 bar / 14.5 psi
- Inlet section: ≥ 5 DN
- Electrical conductivity ≥ 300 μS/cm

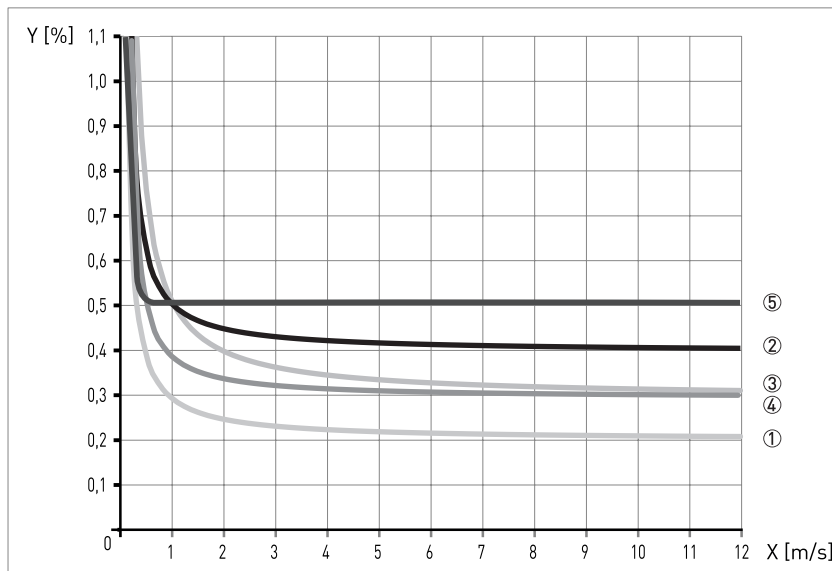

Figure 2-1: Flow velocity vs. accuracy  
 X [m/s] : flow velocity  
 Y [%]: deviation from the actual measured value (mv)

Compact with IMT33A	Accuracy	Curve
DN2.5...6 / 1/10...1/4"	0.3% of MV + 2 mm/s	③
DN10...150 / 3/8...6"	0.2% of MV + 1 mm/s	①

Compact with IMT31A	Accuracy	Curve
DN2.5...6 / 1/10...1/4"	0.4% of MV + 1 mm/s	②
DN10...150 / 3/8...6"	0.3% of MV + 1 mm/s	④
DN10...150 / 3/8...6" * extended calibration	0.2% of MV + 1 mm/s	①

Compact with IMT30A	Accuracy	Curve
DN10...150 / 3/8...6"	0.5% of mv above 0,5 m/s below 0,5 m/s, deviation ± 2.5 mm/s	⑤



### 3.1 Intended use

The measurement of volumetric flowrate of electrically conductive fluids in hygienic applications.

### 3.2 General notes on installation

*Inspect the packaging carefully for damages or signs of rough handling. Report damage to the carrier and to the local office of the manufacturer.*

*Do a check of the packing list to make sure that you have all the elements given in the order.*

*Look at the device nameplate to ensure that the device is delivered according to your order. Check for the correct supply voltage printed on the nameplate.*

#### 3.2.1 Vibration

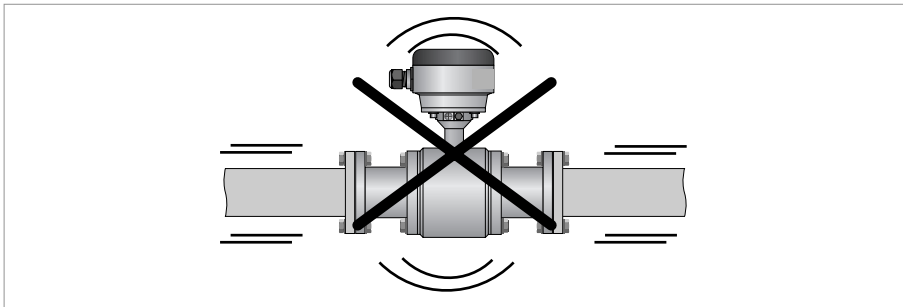

Figure 3-1: Avoid vibrations

#### 3.2.2 Magnetic field

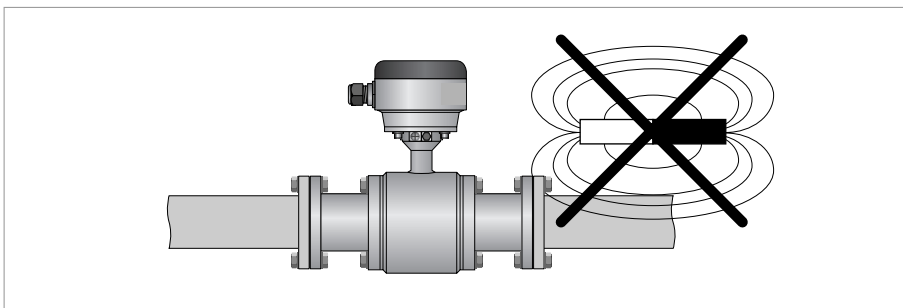

Figure 3-2: Avoid magnetic fields

### 3.3 Installation conditions

#### 3.3.1 Inlet and outlet

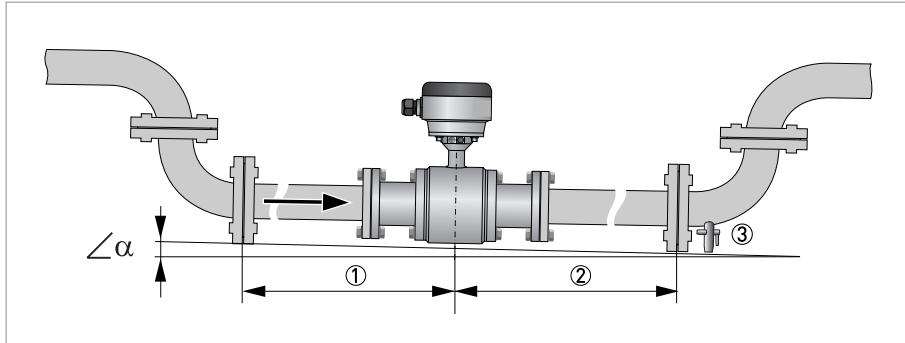

Figure 3-3: Recommended inlet and outlet

- ① Refer to chapter "Bends in 2 or 3 dimensions"
- ②  $\geq 2$  DN
- ③ Drain valve (to empty pipeline)
- $\angle \alpha ; > 2^\circ$

#### 3.3.2 Bends in 2 or 3 dimensions

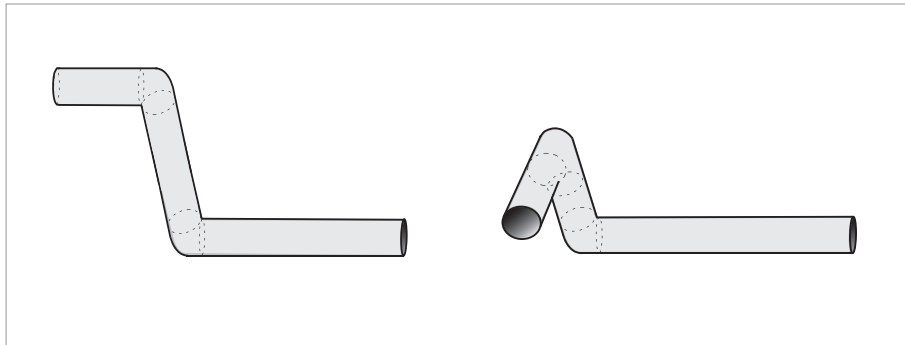

Figure 3-4: Inlet when using 2 and/or 3 dimensional bends in front of the flowmeter

Inlet length: using bends in 2 dimensions:  $\geq 5$  DN; when having bends in 3 dimensions:  $\geq 10$  DN

#### 3.3.3 T-section

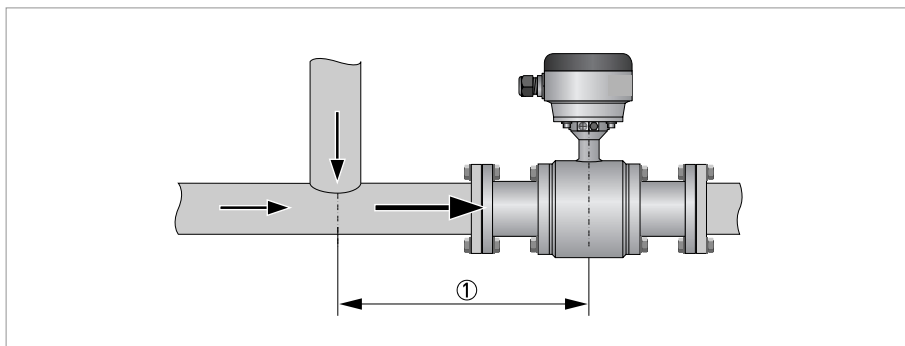

Figure 3-5: Distance behind a T-section

- ①  $\geq 10$  DN

3.3.4 Bends

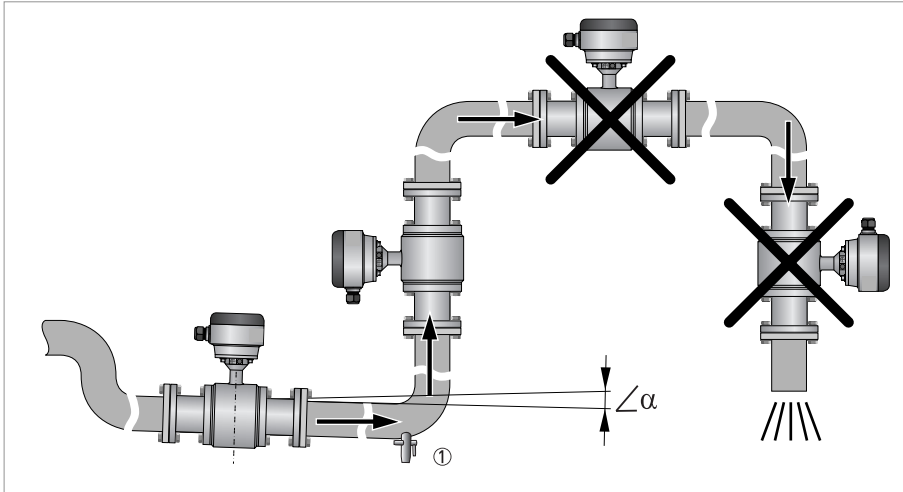

Figure 3-6: Installation in bending pipes

$\angle \alpha ; >2^\circ$

① Drain valve (to empty pipeline)

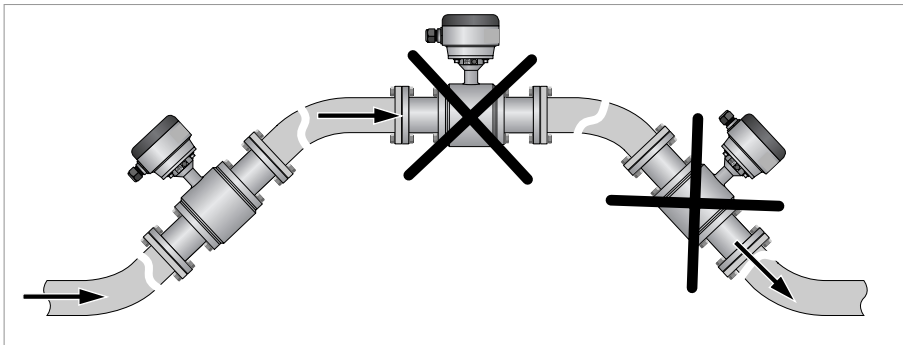

Figure 3-7: Installation in bending pipes

3.3.5 Open discharge

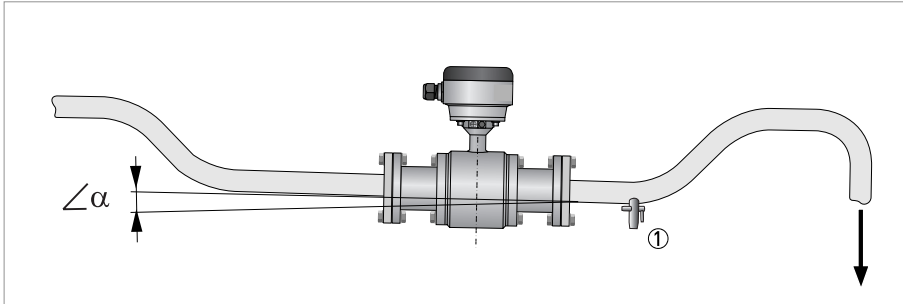

Figure 3-8: Installation in front of an open discharge

$\angle\alpha ; >2^\circ$

① Drain valve (to empty pipeline)

3.3.6 Control valve

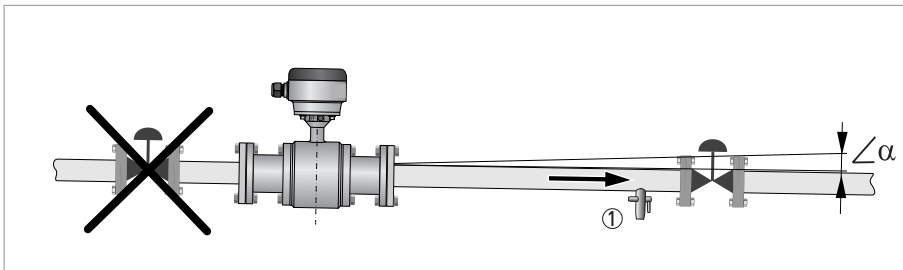

Figure 3-9: Installation in front of a control valve

$\angle\alpha ; >2^\circ$

① Drain valve (to empty pipeline)

3.3.7 Pump

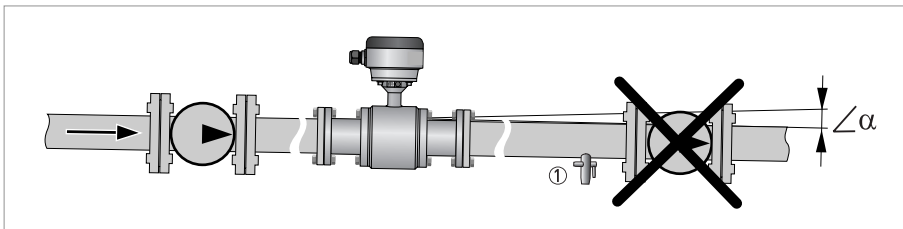

Figure 3-10: Installation behind a pump

### 3.3.8 Air venting and vacuum forces

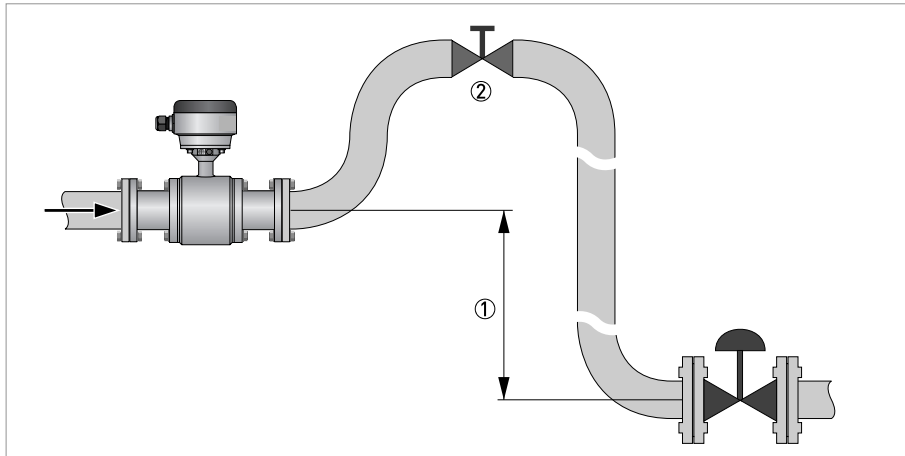

Figure 3-11: Air venting

- ①  $\geq 5$  m
- ② Air ventilation point

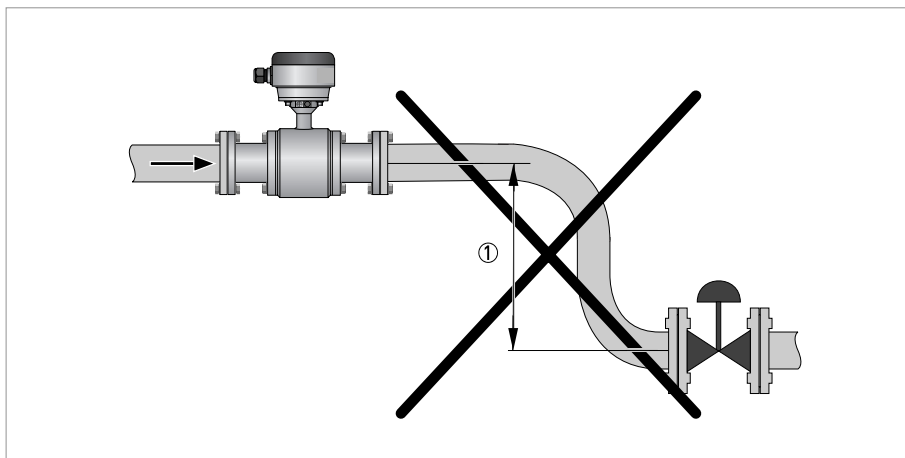

Figure 3-12: Vacuum

- ①  $\geq 5$  m

#### 3.3.9 Mounting requirements for self-draining

*Applicable for 3A marked installations: install flow sensor in vertical pipelines or in pipelines with a minimum slope as indicated!*

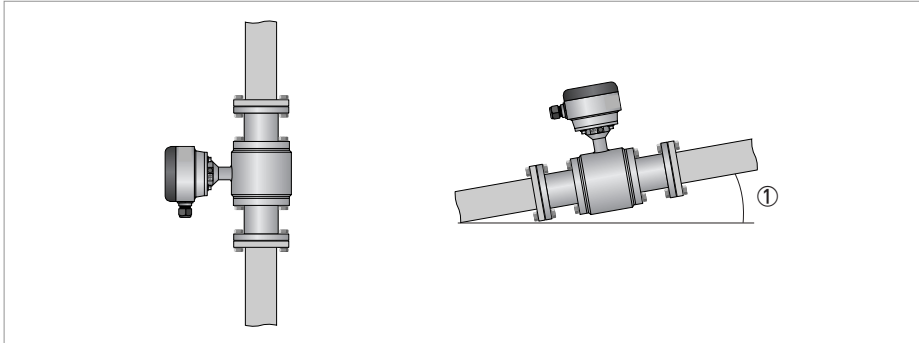

Figure 3-13: Installation note for 3A marked installations

① Minimum slope

#### Minimum slope

Nominal diameter	DIN 11850	ISO 2037	DIN 11864 2A	ISO 2852	DIN 32676	Tri Clamp
2.5...6	10°	10°	-	-	-	-
10	3°	3°	-	-	-	-
15	10°	10°	-	①	-	-
25	10°	3°	10°	3°	10°	3°
40...50	5°	3°	5°	3°	5°	3°
65...80	10°	3°	10°	3°	10°	3°
100	5°	3°	5°	3°	5°	3°
125...150	10°	3°	10°	3°	①	①

① consult factory

### 3.3.10 Flange deviation

Max. permissible deviation of pipe flange faces:  
 $L_{max} - L_{min} \leq 0.5 \text{ mm} / 0.02''$

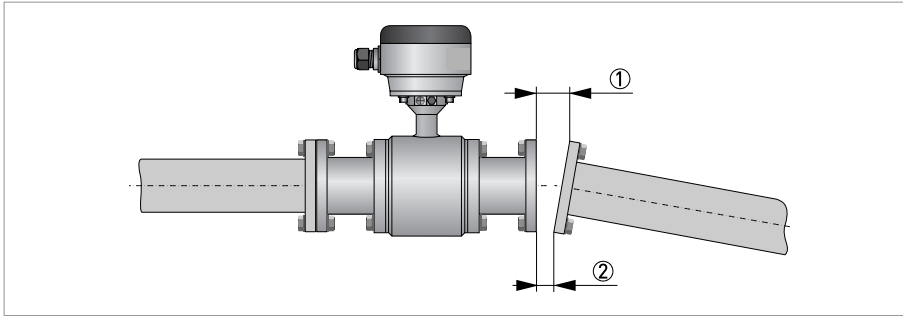

Figure 3-14: Flange deviation

- ①  $L_{max}$
- ②  $L_{min}$

### 3.3.11 Mounting position

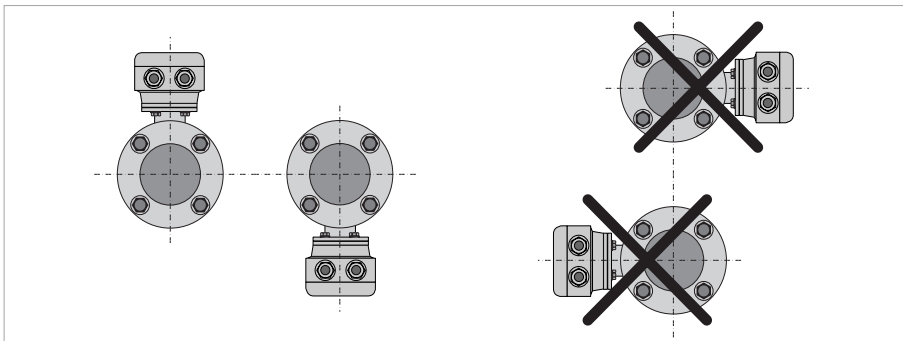

Figure 3-15: Mounting position

- Mount flow sensor either with signal converter aligned upwards or downwards.
- Install flow sensor in line with the pipe axis.
- Pipe flange faces must be parallel to each other.

## 3.4 Mounting

### 3.4.1 Torques and pressures

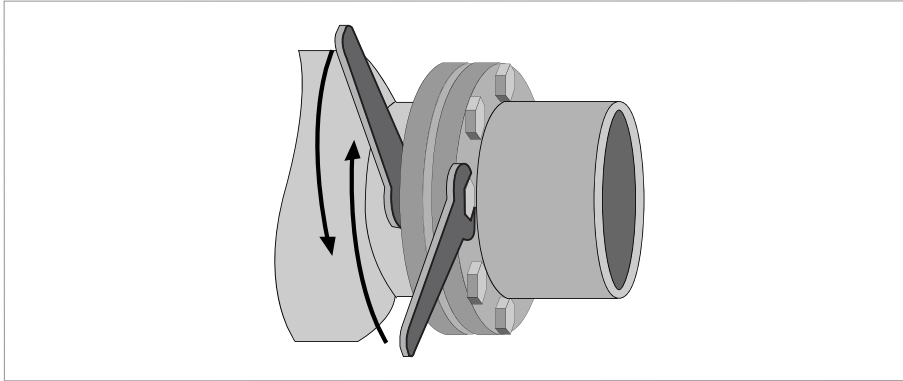

Figure 3-16: Tightening of bolts

*The max. allowable torque depends on the gasket material, see datasheet for detailed information.*

*Bolts to be used from material SS, class 70-A2.*

#### Tightening of bolts

- Always tighten the bolts uniformly and in diagonally opposite sequence.
- Do not exceed the maximum torque value.
- Step 1: Apply approx. 50% of max. torque given in table.
- Step 2: Apply approx. 80% of max. torque given in table.
- Step 3: Apply 100% of max. torque given in table.

#### Maximum torque for 11864-2A flange version

Nominal diameter [mm]	Pressure rating	Bolts	Max. torque [Nm]
25	PN 40	4x M6	7
40	PN 40	4x M8	16
50	PN 25	4x M8	16
80	PN 25	6x M8	16
100	PN 25	6x M8	16
125	PN 10	6x M10	32
150	PN 10	6x M10	32



Type of connection	Size of connection		Max. operating pressure	
	mm	inch	bar	psig
Aseptic weld on for pipes to DIN 11850	DN10...40	-	40	580
	DN50...80	-	25	360
	DN100	-	16	230
	DN125...150	-	10	145
Aseptic weld on for pipes to ISO 2037	12...38	-	40	580
	51...76.1	-	25	360
	101.6	-	16	230
	114.3...139.7	-	10	145
Dairy screw to DIN 11851 ①	DN10...40	-	40	580
	DN50...80	-	25	360
	DN100	-	16	230
	DN125...150	-	10	145
Screwed to SMS 1145 ①	2.5...100	-	6	90
Flanges to DIN 11864-2A	DN25...40	-	40	580
	DN50...80	-	25	360
	DN100	-	16	230
	DN125...150	-	10	145
Clamp joint to ISO 2852	12...51	-	16	230
	63.5...76.1	-	10	145
	100	-	8	115
	114.3...139.7	-	5	72
Clamp joint to DIN 32676	DN25...50	-	16	230
	DN65...150	-	10	145
Clamp joint to Tri Clamp	-	1/2...3	20.5	295
	-	4	13.8	200
	-	5..6	②	②
Vacuum load	all versions and sizes		0 mbar abs.	0 psia

① Without 3A mark

② consult factory

#### 3.4.2 Installation of weld-on versions

For mounting sensors with weld-on connections, please follow the procedure as follows:

- Mount the sensor completely in the pipeline and spot the weld-on connections to the pipe. This is necessary to align the mounting bores of the flange.
- Remove the sensor body and the gaskets from the adapters by loosen the screws.
- Weld the adapters completely to the pipe.
- When the pipe is cold again, reinstall the gasket and mount the sensor.

#### 3.4.3 Temperatures

*Protect the device from direct sunlight.*

##### Ambient temperature

	°C		°F	
	min.	max.	min.	max.
Separate flow sensor Compact version with; IMT30A, IMT31A & IMT33A	-40	65	-40	149

##### Maximum process temperature

Type of connection	Separate flow sensor		Compact + IMT30A & IMT31A		Compact + IMT33A	
	°C	°F	°C	°F	°C	°F
Aseptic weld on for pipes to DIN 11850	140	284	120 ①	248 ②	140	284
Aseptic weld on for pipes to ISO 2037	140	284	120 ①	248 ②	140	284
Dairy screw to DIN 11851 ③	140	284	120 ①	248 ②	140	284
Screwed to SMS 1145 ③	140	284	120 ①	248 ②	140	284
Flanges to DIN 11864-2A	140	284	120 ①	248 ②	140	284
Clamp joint to ISO 2852	120	248	120	248	120	248
Clamp joint to DIN 32676	140	284	120 ①	248 ②	140	284
Clamp joint to Tri Clamp	120	248	120	248	120	248

① 140°C if ambient temperature ≤ 40°C

② 284°F if ambient temperature ≤ 104°F

③ Without 3A mark

### 3.4.4 Cleaning

*In principle, no special maintenance is needed. However, make sure that the used cleaning product doesn't affect the outer surface and the gaskets.*

## 4.1 Safety instructions

*All work on the electrical connections may only be carried out with the power disconnected. Take note of the voltage data on the nameplate!*

*Observe the national regulations for electrical installations!*

*For devices used in hazardous areas, additional safety notes apply; please refer to the Ex documentation.*

*Observe without fail the local occupational health and safety regulations. Any work done on the electrical components of the measuring device may only be carried out by properly trained specialists.*

*Look at the device nameplate to ensure that the device is delivered according to your order. Check for the correct supply voltage printed on the nameplate.*

## 4.2 Grounding

*The device must be grounded in accordance with regulations in order to protect personnel against electric shocks.*

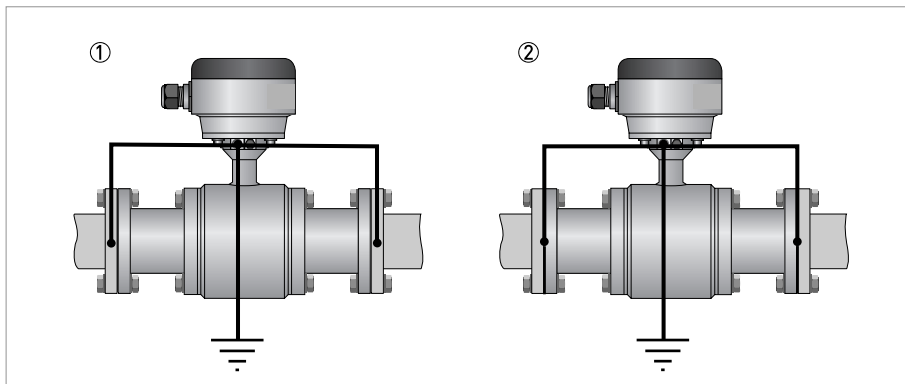

Figure 4-1: Grounding options

1. Grounding option without grounding rings
2. Grounding option with grounding rings

### 4.3 Virtual reference for IMT33A (C, W and F version)

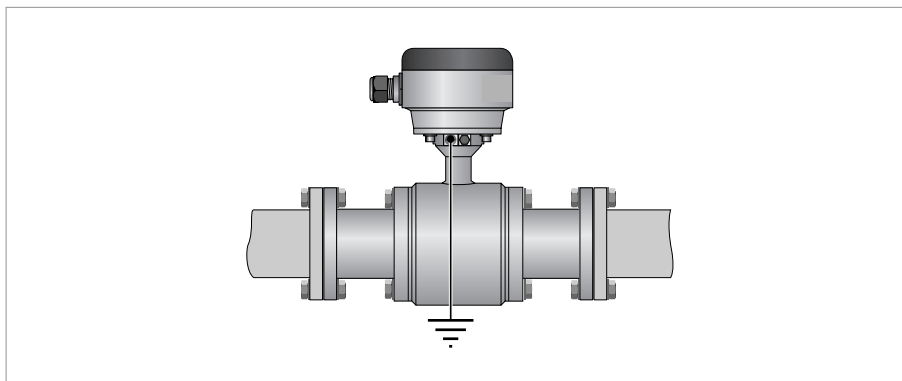

Figure 4-2: Virtual reference

**Minimum requirements:**

- Size:  $\geq$  DN10
- Electrical conductivity:  $\geq$  200  $\mu$ S/cm
- Signal cable: max. 50 m / 164 ft, type DS

### 4.4 Connection diagrams

*For the connection diagrams please refer to the documentation of the applicable signal converter.*

Model	Description
	Foxboro® Model 9600A Magnetic Flow Sensor
960TA 960SA 960QA 963EA 96HAA 9601A 961HA 9602A 962HA 9603A 9604A 9605A 9606A	<b>Nominal diameter and liner</b> DN 2.5...1/10" - PFA DN 4...1/8" - PFA DN 6... 1/4" - PFA DN 10...3/8" - PFA DN 15...1/2" - PFA DN 25...1 - PFA DN 40...1 1/2" - PFA DN 50...2" - PFA DN 65...2 1/2" - PFA DN 80...3" - PFA DN 100...4" - PFA DN 125...5" - PFA DN 150...6" - PFA
-H -K -L -N -P -S -T -U	<b>Nominal pressure and connection</b> DIN 11851 - dairy screw connection SMS 1145 - dairy screw connection ISO 2852 - clamp connection DIN 32676 - clamp connection Tri CLAMP - clamp connection DIN 11850 - weld-end connection ISO 2037 - weld-end connection DIN 11864-2A- flange connection
0 1 3 5 A C	<b>Ex version</b> Non Ex Ex Zone 1 IMT33A compact [DN 2,5...80] & field [DN 25...80] & IMT31A wall [25...80] Ex Zone 2 (IMT33A compact and field) FM Class I DIV 2 (IMT33A Field [DN 2,5...15] ) cCSAus OL (IMT33A compact / field / wall & IMT31A compact / wall) CSA Class I DIV 2
1 2 3 4 5 6 A B C	<b>System design</b> Compact with aluminum converter housing / at converter Compact with stainless steel converter housing / at converter Modular / without Separate with aluminum connection box / 1/2" NPT Separate with aluminum connection box / PF 1/2 Separate with aluminum connection box / M20 x 1.5 A Separate with stainless steel connection box / 1/2" NPT Separate with stainless steel connection box / PF 1/2 Separate with stainless steel connection box / M20 x 1.5
0 3 4 C D E F K L	<b>Converter model</b> Without / modular IMT31A (compact design) IMT31A (wall mount version) IMT33A (compact design) IMT33A (field mount version) IMT33A (wall mount version) IMT33A (rack mount version) IMT30A (compact design) [DN 10...150   3/8"...6"] IMT30A (wall mount version) [DN 10...150   3/8"...6"]
0	<b>Mounting Material</b> Without
0 D	<b>Grounding ring material</b> Without / L-profile O-ring EPDM (aseptical connection) Without / L-profile O-ring silicone (aseptical conn)

Model	Description
1 3 4 5 6 7 A B	<b>Electrodes (fixed)</b> St.Steel 1.4571 / 316Ti (DN 2,5...15   1/10" ...1/2") Hastelloy C4 (DN 2,5...15   1/10" ...1/2") Hastelloy B2 (DN 2,5...15   1/10" ...1/2") Tantalum (DN 2,5...15   1/10" ...1/2") Titanium Platinum (wetted parts) (DN 2,5...15   1/10" ...1/2") St.Steel 1.4404/316L (DN 25...100   1" ...4") Hastelloy C22 DN 2,5...150   1/10" ...6")
0 1 2	<b>Protection class / dimension ( face-to-face )</b> IP 66 / 67 / standard IP 68 Filled / standard (with stainless steel connection box) IP 68 Factory / standard (with stainless steel connection box)
0 1 2 Y	<b>Cable</b> Compact - without / separate DS Separate BTS Separate LIYCY (only for FM / CSA Class 1 DIV 2) Without
0 1 2 3 4 5 6 7 8 Y	<b>Cable length</b> Compact - none / separate - 5 m   15 ft 10 m   30 ft 15 m   45 ft 20 m   60 ft 25 m   75 ft 30 m   90 ft 40 m   120 ft 50 m   150 ft 100 m   300 ft Without
0 2 3	<b>Calibration</b> Standard 316/1.4401 tag plate (120 x 46 mm) 316/1.4401 tag plate (67 x 25 mm)
0	<b>Construction requirements</b> Standard
0	<b>QA / QC requirements</b> Standard
0	<b>Ratio of CT-calibration</b> Standard, R=80

## ORDERING INSTRUCTIONS

1. Model Number.
2. Flow Data:
  - a. Maximum, minimum, and normal flow rate.
  - b. Fluid composition and viscosity at operating temperatures.
  - c. Fluid density or relative density (specific gravity).
  - d. Maximum, minimum and normal operating temperatures.
  - e. Maximum, minimum and normal operating pressures.
  - f. Mating pipe schedule.
  - g. Type and location (distance) of upstream disturbance.
3. Calibration Information (analog output only); maximum flow rate 20 mA output.
4. Electric Classification.
5. Operational Selection and Accessories (see "Optional Selections and Accessories" section).
6. Customer Tag Data.

## FLOWEXPERTPRO SIZING APPLICATION

Mobile application    FlowExpertPro.com



## OTHER FOXBORO PRODUCTS

The Foxboro product lines offer a broad range of measurement and instrument products, including solutions for pressure, flow, analytical, temperature, positioning, controlling and recording. For a list of these offerings, visit our website at:

[www.fielddevices.foxboro.com](http://www.fielddevices.foxboro.com)